



The MRP Challenge



MRP exercise

Example

Item ID: A

Lot Size	POS4
Low Level	0
On-Hand	100
Lead Time	3
Allocation	15
Safety Stock	25

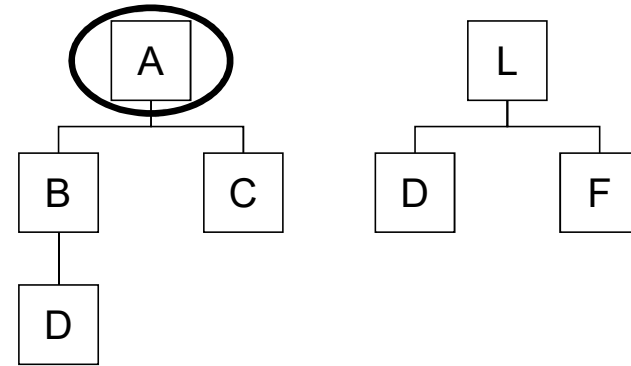

	Past	1	2	3	4	5	6	7	8
Requirement									
Projected On Hand									
Scheduled Receipts									
Planned Order Receipts									
Planned Order Releases									

Example

Item ID: L

Lot Size	250
Low Level	0
On-Hand	50
Lead Time	6
Allocation	0
Safety Stock	100

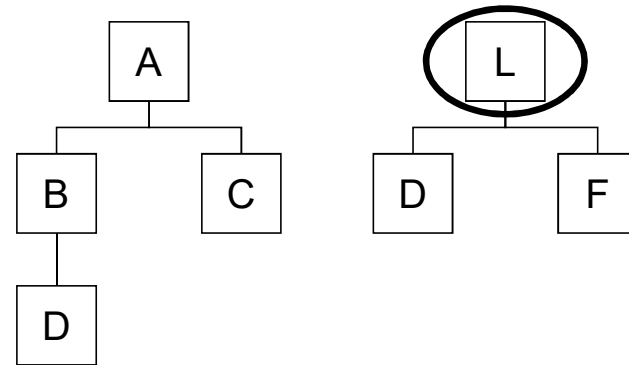

	Past	1	2	3	4	5	6	7	8
Requirement									
Projected On Hand									
Scheduled Receipts									
Planned Order Receipts									
Planned Order Releases									

Example

Item ID: B

Lot Size	100
Low Level	1
On-Hand	50
Lead Time	4
Allocation	0
Safety Stock	0

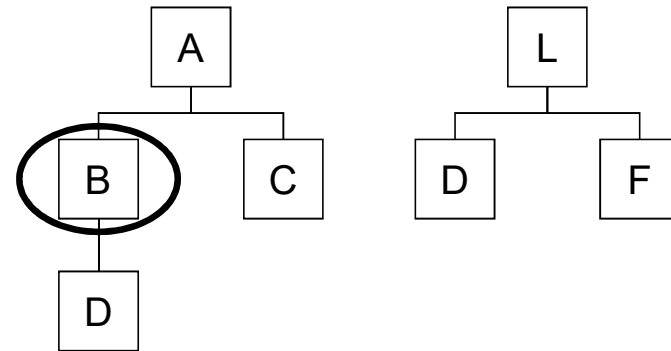

	Past	1	2	3	4	5	6	7	8
Requirement									
Projected On Hand									
Scheduled Receipts									
Planned Order Receipts									
Planned Order Releases									

Example

Item ID: D

Lot Size	1000
Low Level	2
On-Hand	200
Lead Time	8
Allocation	0
Safety Stock	100

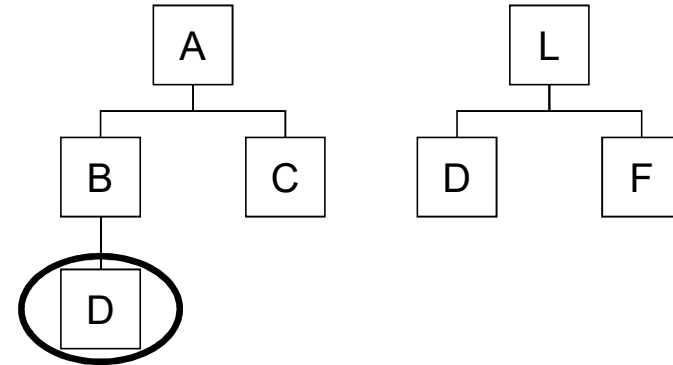

	Past	1	2	3	4	5	6	7	8
Requirement									
Projected On Hand									
Scheduled Receipts									
Planned Order Receipts									
Planned Order Releases									

THE authoritative book on
Demand Driven Material
Requirements Planning

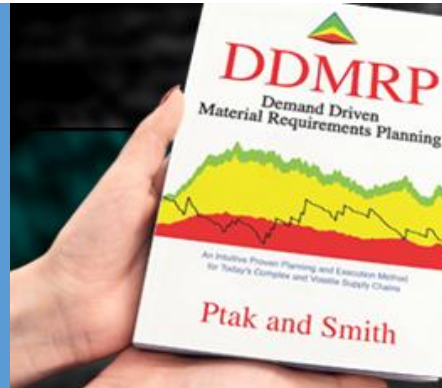

YOUR PATH TO BECOME
DEMAND DRIVEN
STARTS HERE



THE authoritative education
on Demand Driven Material
Requirements Planning

www.demanddriveninstitute.com



All contents © copyright 2016 Demand Driven Institute, all rights reserved.

7

